

Plan View Elevation

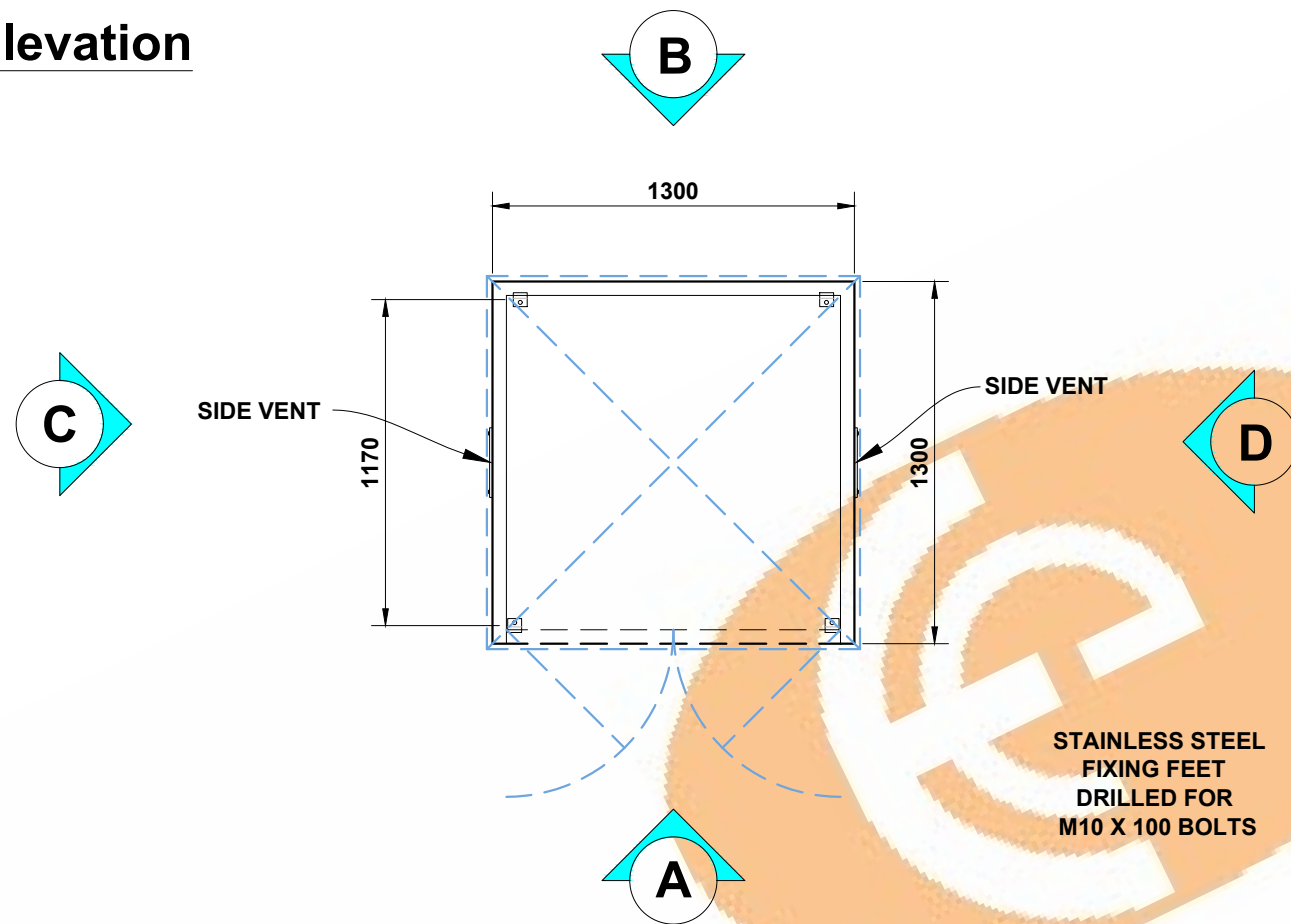

Open Side View

ROOF HINGED AT BACK WITH ALLOY HINGES & SECURED INSIDE FRONT BY SHOOT BOLTS & BY INTERNAL FIXING STAY WHEN RAISED

REAR INSPECTION FLAP SUSPENDED ON STAINLESS STEEL HINGE & SECURED BY STAINLESS STEEL HASP & STAPLE. FOR 10mm HASPS

2 OFF GALVANISED STEEL VENT BLOCKS 250 X 200mm TO PROVIDE LOW & HIGH LEVEL VENTILATION (1 EACH SIDE)

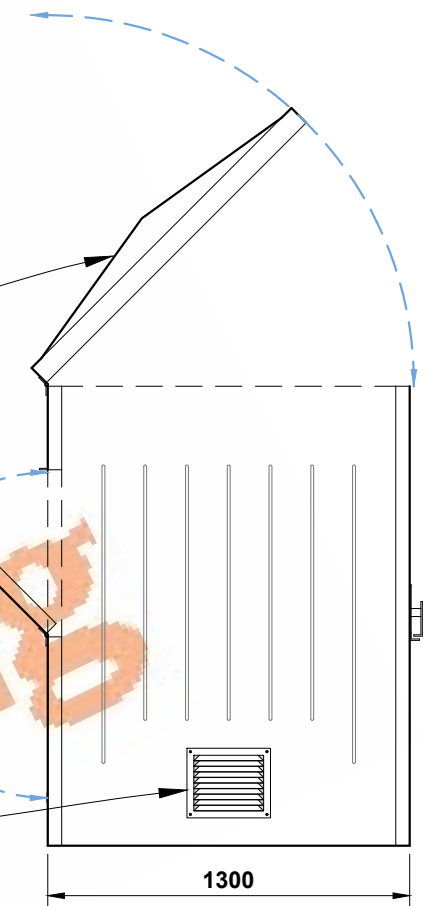

Elevation (A) (front)

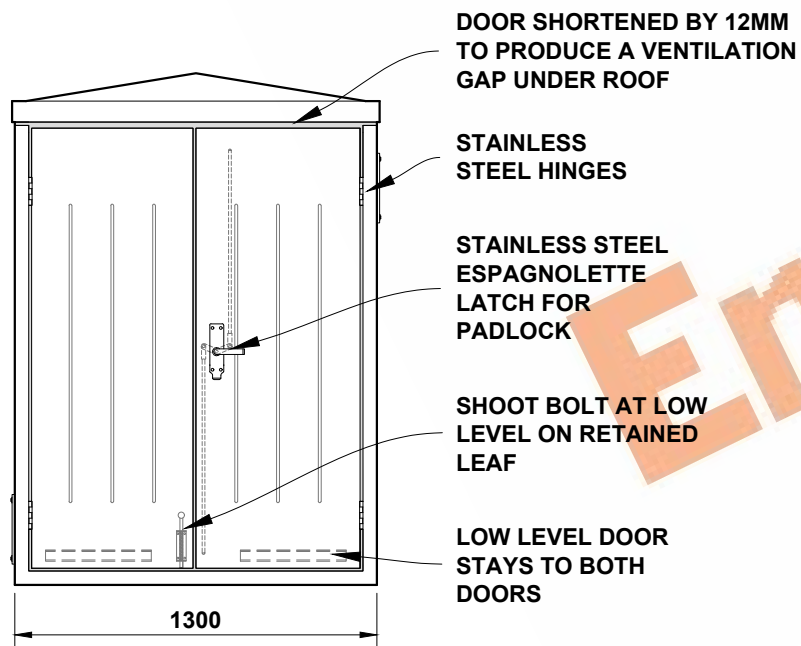

Elevation (B) (rear)

ROOF HINGED AT BACK WITH ALLOY HINGES & SECURED INSIDE FRONT BY SHOOT BOLTS & BY INTERNAL FIXING STAY WHEN RAISED

REAR INSPECTION FLAP SUSPENDED ON STAINLESS STEEL HINGE & SECURED BY STAINLESS STEEL HASP & STAPLE. FOR 10mm HASPS

STAINLESS STEEL PROTECTION PAD FOR WHEN INSPECTION FLAP IS IN OPEN POSITION

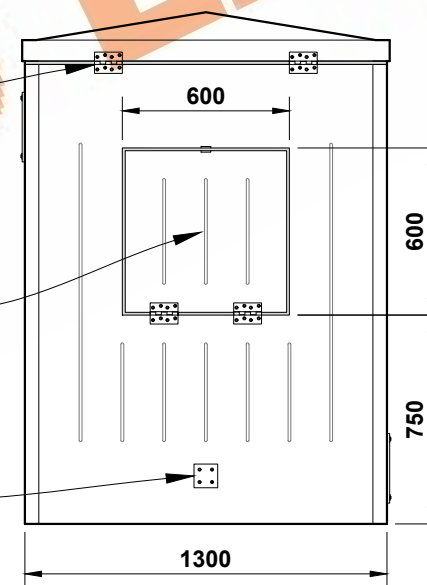

Elevation (C) (l/h side)

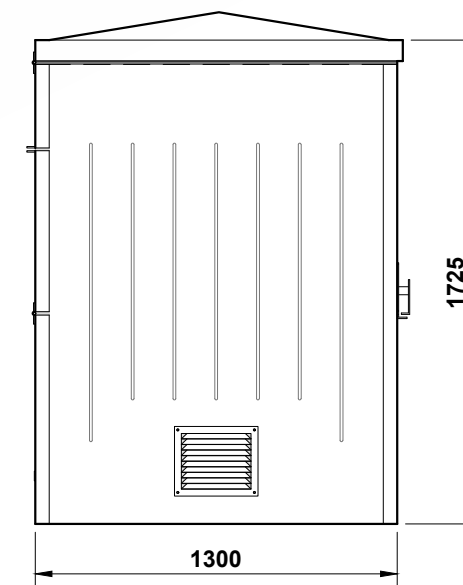

Elevation (D) (r/h side)

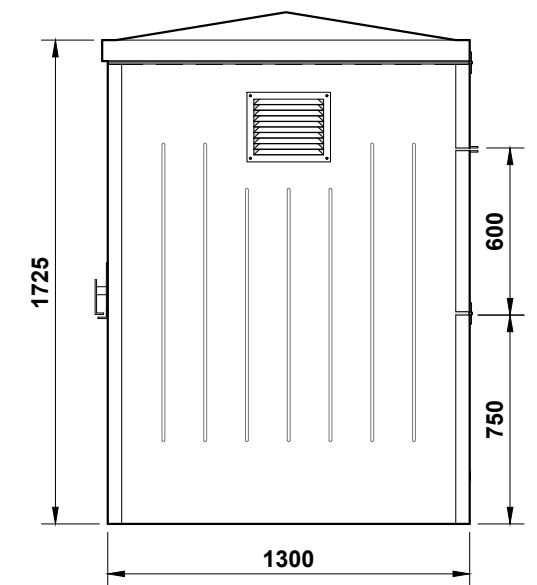

THE DRAWING AND DESIGN IS THE PROPERTY OF ENVICO ENGINEERING LTD. AND WITHOUT THE WRITTEN CONSENT OF ENVICO ENGINEERING LTD. MAY NOT BE COPIED IN WHOLE OR IN PART OR COMMUNICATED TO A THIRD PARTY OR USED FOR ANY PURPOSE.

Envico Engineering Limited

Tel : 01792 794 619

Fax : 01792 793 532

Nantyffin Road (South), Enterprise park, Llansamlet
Swansea, SA7 9RG, South Wales.

INTERNAL WIDTH : 1190mm

INTERNAL DEPTH : 1190mm

INTERNAL HEIGHT : 1725mm

APPROX. WEIGHT : 155kg

Date : 14/02/2017

Drawn By : D O'Malley

GRP HOUSING : TRANSFORMER TYPE TR8

Drawing Scale : Not To Scale

Drawing No : TR8

Rev :