

# Roadside Range

In 1965 Morgan Marine developed their first GRP Cabinets for the cathodic protection industry to withstand the harsh marine environment encountered offshore.

The units soon gained a name for quality, durability and corrosion resistance. As applications were identified in the onshore market the advantages of low maintenance, low life cycle cost and rugged construction led to the expansion of the range.

The range now includes products ideally suited to the market sector which includes the power, communication and utility companies.

As well as our standard sizes, we manufacture specials to meet the customer's individual requirements, either as modified standard units or as special mouldings.

We endeavour to keep a good level of Roadside Housings and Kiosks in stock at all times. We try to offer our Roadside Range as an "off the shelf" product ready for despatch nationwide by national Carrier at short notice.



## Morgan Marine Ltd.

Sales, Engineering and Manufacturing

Llandybïe, Ammanford, Carmarthenshire SA18 3JG

Tel: 44 (0)1269 850437 Fax: 44 (0)1269 850656

E-mail: sales@morgan-marine.com

Website: www.morgan-marine.com



# Technical Specifications

## Roadside Construction

Moulded in Glass Reinforced Polyester composite using self-extinguishing, fire retardant resin, tested to BS476: Part 7, Class 2.

Cabinets have a plain semi-gloss surface and can be manufactured in any of the full range of BS4800 colours to order.

Doors are offered with a choice of cylinder night latch lock or hasp and staple. Other door fittings or locks can be supplied to order. Double door units are fitted with tower bolts. Doors are reinforced to provide a high level of security and are dust and weather-proofed to IP54 in accordance with BS5490: 1977, IEC.529: 1979. Higher performance doors to protection classifications IP55 are available on request.

Electrical installations encompassing domestic to Zone 1 electrical services, including customer supplied equipment, can be fitted in accordance with the current IEE Regulations.

Standard units have an open base with an integral flange. Integral composite floors are available (standard on Type P, Torbette and Meter Cabinet). Standard fixing is through reinforced internal flanges by rawbolts on to prepared concrete bases. Alternatively, most units can be wall mounted.

Roadside Cabinets can be supplied with many options including: Internal Mounting Board, Wired Glass Window, Clamp Latches, Cable Entry Flap, Ventilators, Lighting, Heating and Gland Plates.

Whilst every care is taken the preparation of this publication, it is not considered as binding in detail unless confirmed by us. Due to our process of continual improvement we reserve the right to make any alteration without notice

# Base Fixing Details

## STEPPED CONCRETE BASE: RECOMMENDED.

Morgan Marine Ltd cannot be held responsible for sealing on a flat plinth. Any failure in the seal resulting in subsequent site visits would be chargeable. The step will affect clear internal height, ie a 50mm step will reduce the internal height quoted by 50mm

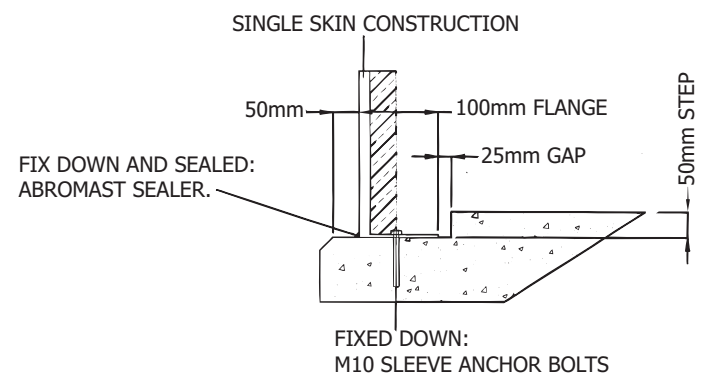

# Morgan Roadside Range



# Cabinets & Transformer Housings



# Morgan Roadside

## Transformer Housing

Morgan Marine specifically designed a transformer housing of a robust but lightweight design. This housing incorporates high and low ventilation to disperse the heat emitted from the transformer; explosion-relieving roofs are optional.

The large double doors at the front give easy access and are fitted with a padlockable two point locking system.

The housing has been independently tested by the building Research Establishment to ensure it meets the required criteria.

Transformer housings have many other uses; please call to discuss your requirements.



# Morgan Roadside

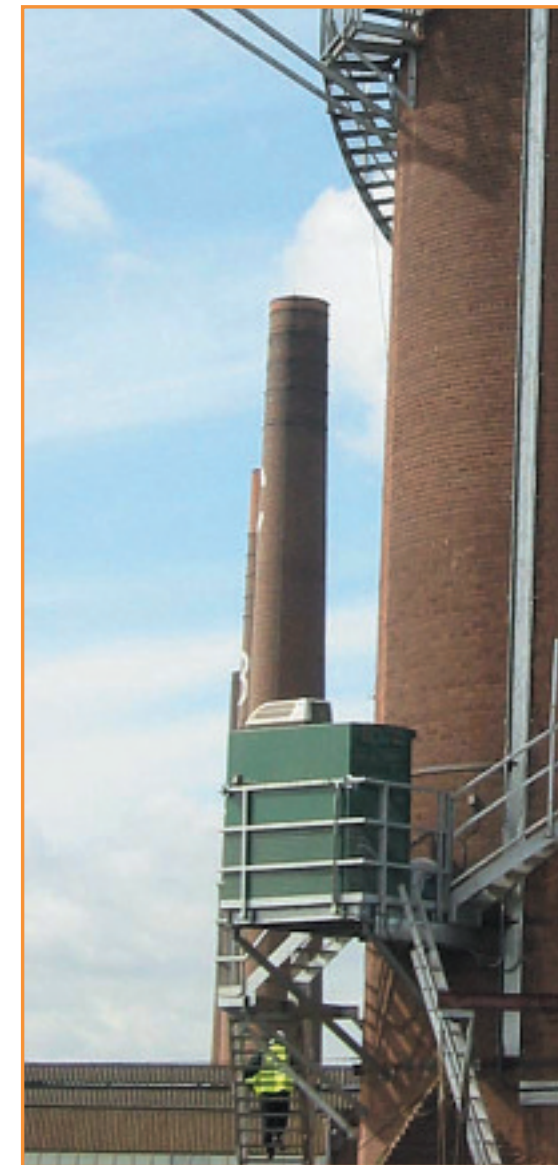

## Double Door Housings

The Double Door range of cabinets are widely used within every major Water Authority, by the Power and Gas suppliers and used heavily within the Communications Industry.

All double door housings are supplied with tower bolts and the four larger kiosks in the range also have door-stays fitted as standard.

With a choice of cylinder night latch lock or a hasp & staple fitting, these kiosks can also be supplied with plywood backboards, basic electrical fitting and ventilation options.

Typical uses are in air quality monitoring, at pumping stations and for MCC protection nationwide.

# Morgan Roadside

## Single Door Housings

The Single Door cabinets are ideally suited to house and protect instrumentation and control panels, on a smaller scale. These smaller units are often supplied to Local Authorities, The Environment Agency, Network Rail and the MOD for a wide range of uses.

Single door units are often offered with a choice of a cylinder night latch lock or a hasp & staple and can be pre-fitted with plywood backboard for fixing.

Typically these units are used to house small electrical components, standpipes, telemetry equipment and as sampling kiosks.



Morgan Marine offer both the double and single door cabinets and kiosks manufactured in steel, galvanised steel and stainless steel.

The steel kiosk range is offered in a full range of powder coated finishes.

## Transformer Housing

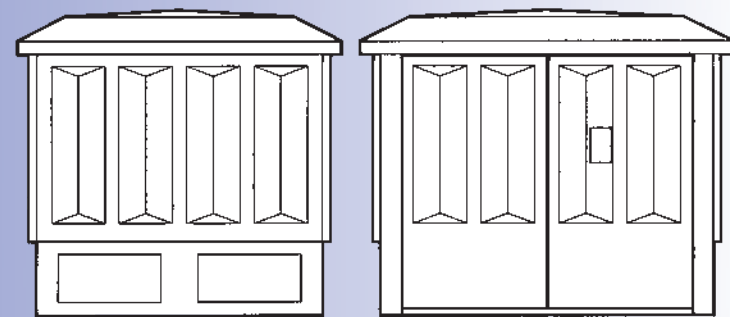

## Transformer Housing

Transformer Housing	
<b>Width</b>	
<i>External</i>	2760
<b>066Height</b>	
<i>Clear Internal</i>	2200
<b>Depth</b>	
<i>External</i>	2685
<b>Door</b>	
<i>Clear Width</i>	2270
<i>Clear Height</i>	1990
<b>Sill</b>	
	70

## Double Door Composite Cabinets

Double Door Units	Type E	Type F	Type G	Type H	Type J	Type M	Type O
	<b>Width</b>						
<i>External</i>	2010	2010	2010	1760	1410	1065	1065
<i>Internal</i>	1890	1980	1990	1730	1390	1010	1010
<b>Height</b>							
<i>Maximum</i>	2255	2255	1585	1580	1515	1275	1270
<i>Minimum</i>	2215	2215	1540	1540	1465	1220	1235
<b>Depth</b>							
<i>External</i>	1750	1250	800	790	660	660	460
<i>Internal</i>	1680	1180	740	730	605	580	400
<i>Maximum (Top)</i>	1860	1360	910	900	775	745	530
<b>Door</b>							
<i>Clear Width</i>	1735	1735	1730	1485	1165	860	860
<i>Clear Height</i>	2000*	2000*	1305	1310	1220	860	860
<b>Sill</b>							
<i>Height</i>	45*	45*	70	70	120	240	240

\* denotes removable sill

## Single Door Composite Cabinets

Single Door Units	Type S	Type R	Type P	Torbay	Double Torbay	Torbette	Meter Cabinet	Feeder Pillar
	<b>Width</b>							
<i>External</i>	900	900	630	640	640	640	460	340
<i>Internal</i>	890	890	620	630	630	630	450	330
<b>Height</b>								
<i>Maximum</i>	1175	1175	1165	1135	1135	910	615	860
<b>Depth</b>								
<i>External</i>	545	330	370	300	530	300	300	210
<i>Internal</i>	500	280	320	250	450	250	265	135
<i>Maximum (Top)</i>	600	385	430	355	570	355	300	210
<b>Door</b>								
<i>Clear Width</i>	750	750	485	490	490	490	370	240
<i>Clear Height</i>	710	710	710	720	720	720	520	710
<b>Sill</b>								
<i>Height</i>	290	290	300	300	300	80	45	95